



Getting to Know Your 2007 Terraza



Table of Contents

DRIVER INFORMATION	OnStar®	14
Instrument Panel	Power Sliding Doors	14
Instrument Panel Cluster	Rear Seat Climate Control with RSE	15
Driver Information Center (DIC)	Folding Rear Seats	15
REMOTE KEYLESS ENTRY	Side-Folding Utility Tray	16
Remote Keyless Entry (RKE)	Convenience Center	16
Remote Vehicle Starter System	Child Restraints (LATCH)	16
ENTERTAINMENT	Overhead Rail System Modules	17
Audio Systems	115-Volt Power Outlet	17
Multiple-Disc CD Changer	Air Inflator Tools	17
Touch Screen Navigation	Ultrasonic Rear Park Assist (URPA)	17
Entertainment System	PERFORMANCE & MAINTENANCE	
Rear Seat Entertainment (RSE) System	Automatic Level Control	18
(DVD Player)	Traction Control	18
Steering Wheel Audio Controls	StabiliTrak® – Stability Control System	19
CONVENIENCE	Proper Tire Pressure	19
Daytime Running Lamps (DRL)	Service Intervals	19
Interior Lamps	FlexFuel (E85) – Yellow Gas Cap	19
Cruise Control	OWNER INFORMATION	
Window Washer Fluid	Roadside Assistance	20
Passenger Air Bag Status Indicator	My GMLink	20
Universal Home Remote		

Congratulations on your purchase of a Buick Terraza. Please read this information and your Owner Manual to ensure an outstanding ownership experience. Note that your vehicle may not include all the features described in this booklet. Keep this booklet with your Owner Manual for easy reference.

DRIVER INFORMATION

Instrument Panel

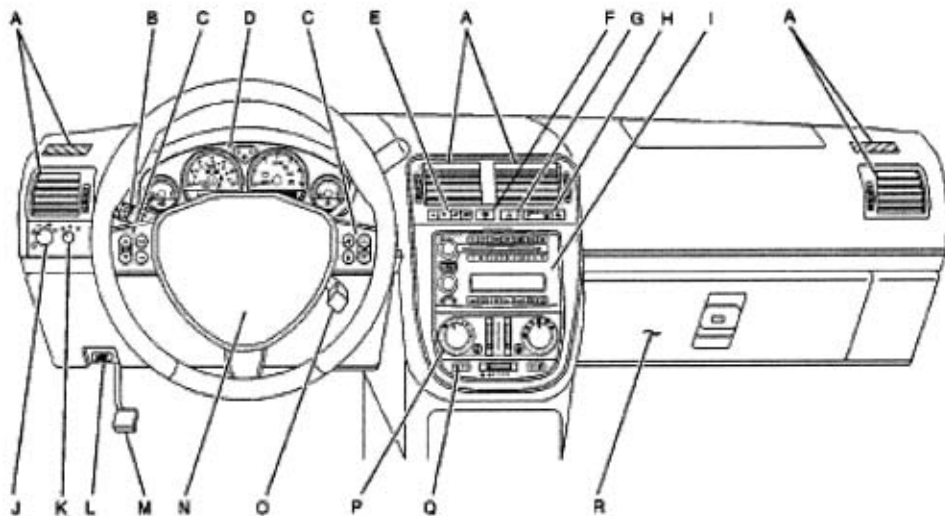

- | | | |
|------------------------------------|---------------------------------------|-------------------------|
| A. Air Outlets | H. Passenger Air Bag Status Indicator | N. Horn |
| B. Turn Signal/Multifunction Lever | I. Audio System | O. Cruise Controls |
| C. Steering Wheel Audio Controls | J. Exterior Lamps Control | P. Climate Controls |
| D. Instrument Panel Cluster | K. Interior Lamps Control | Q. Heated Seat Controls |
| E. DIC Controls | L. Hood Release | R. Rear Fan Control |
| F. Traction Control Button | M. Parking Brake | S. Glove Box |
| G. Hazard Warning Flashers Button | | |

See Section 3 of your Owner Manual.

Instrument Panel Cluster

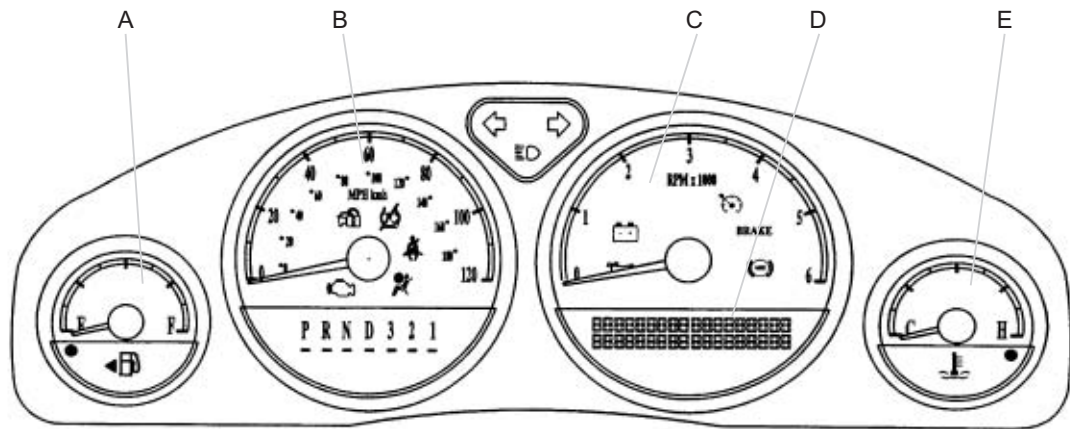

Your vehicle's instrument panel is equipped with this cluster or one very similar to it. The instrument panel cluster includes these key features:

- A. Fuel Gauge
- B. Speedometer

- C. Tachometer
- D. Driver Information Center Display/Odometer
- E. Engine Coolant Temperature Gauge

Note: The instrument panel cluster is designed to let you know about many important aspects of your vehicle's operation. It is important to read your Owner Manual and become familiar with the information being relayed to you by the lights, gauges, DIC messages and indicators, as well as what action can be taken to ensure safety and to prevent damage.

See Section 3 of your Owner Manual.

Driver Information Center (DIC)



Your vehicle's Driver Information Center, located below the tachometer in the instrument panel cluster, can display trip information, fuel economy information, personalization features and other vehicle messages and warnings.



The DIC controls are located on the instrument panel to the right of the steering wheel.

Vehicle Information

Press the **i** (Information) button to scroll up or down through the following Vehicle Information selections:

- Dual Trip Odometers (Trip A and Trip B)
- Time Elapsed
- Average Speed
- Fuel Range (approximate miles until empty)
- Average Fuel Economy
- Instantaneous Fuel Economy
- Battery Voltage
- Oil Life (percentage of engine oil life remaining before an oil change is needed. This service should be

performed within 600 miles of the Change Oil Soon message being displayed)

Resetting Vehicle Information

1. Display the information selection to be reset by pressing the **i** (Information) button.
2. Press and hold the **←** (Set/Reset) button until the selection resets.

Note: The Oil Life System must be reset after each oil change to help ensure the proper maintenance of your vehicle. Use the procedure described above to reset the Oil Life System.

Trip Odometer Reset

The trip odometer has a retroactive reset feature, which sets the trip odometer to the number of miles driven since the ignition was last turned on. This can be useful if you forget to reset the trip odometer before beginning a trip.

To use the retroactive reset feature, push and hold the trip/reset button for at least six seconds.

Note: If the Remote Vehicle Starter System is used to start the vehicle, the trip odometer will not recognize that ignition cycle and will set the trip odometer to the number of miles driven since the last key-start ignition cycle.

Display Units and Language

Press the **☰** (Menu) button to scroll through the following features:

- Display Units — The units of measure in which information will be displayed
- Language — The DIC display language

Personal Program and Compass (if equipped)





Press the  (Menu) button to scroll through the following features:

- Personal Program — Certain features that may be programmed to your personal preference
- Compass Zone — The compass can be set for one of 15 geographic zones
- Compass Calibration — Adjusts for compass variance and zone

To display the odometer, press the  (Information) button.

Personal Program

You can personalize the operation of a variety of features on your vehicle. To scroll through the features that can be personalized using the DIC:

1. Turn on the ignition and place the vehicle in Park.
2. Press the  (Menu) button until PERSONAL PROGRAM is displayed.
3. Press the  (Set/Reset) button to begin.
4. Press the  button to display each available feature.
5. Press the  button to change the setting of each feature.

Personal Program features may include:

- Factory Default — Resets all Personal Program features to the factory settings
- Exterior Light Delay — The amount of time the exterior lamps will remain on after the vehicle is turned off

- Interior Lights Key Removed — The interior lights will remain on a short period after the key is removed from the ignition
- Delayed Locking — Locks all doors a few seconds after all doors have been properly closed
- Content Theft — The status of the Content Theft-Deterrent System alarm
- FOB Lock Feedback — The feedback received when locking the vehicle with the RKE transmitter
- Remote Start — The status of the Remote Start function
- Rear Park Chime — Warning chimes sound when the system detects a person or object close to the rear of the vehicle when in Reverse
- Personalize Key — Saves radio station presets and Personal Program selections to a specific ignition key
- Automatic Door Unlocking — Automatically unlocks the driver's door or all doors
- Auto Unlock On — Unlocks the driver's door or all doors when the key is removed from the ignition or when the vehicle is shifted into Park
- FOB Unlock on First Press — The first press of the unlock button on the RKE transmitter will unlock the driver's door or all doors

To exit Personal Program, you must press the Unlock button on the RKE transmitter (key fob). This will save all settings.

To display the odometer, press the  (Information) button.

Compass

Your vehicle's compass is self-calibrating. However, it may be necessary under certain circumstances, such as during a long-distance cross-country trip, to compensate for compass variance and reset the compass zone through the DIC. Refer to the calibration procedure in your Owner Manual for more details.

See Section 3 of your Owner Manual.

REMOTE KEYLESS ENTRY

Remote Keyless Entry (RKE)

This feature allows you to lock or unlock your vehicle's doors, open or close the power sliding door(s) (if equipped) and sound an alarm using the RKE transmitter (key fob).

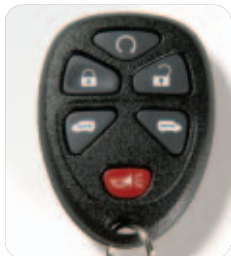

Locking the Doors

- Press  on the RKE transmitter.

Unlocking the Doors



- Press  on the RKE transmitter once to unlock the driver's door. Press the button again within five seconds to unlock all doors.

Sounding the Panic Alarm

- Press  on the RKE transmitter when the ignition is turned off. The horn will sound and the parking lamps and headlamps will flash for up

to two minutes. To cancel the panic alarm, press the button again or insert the key in the ignition and turn it to the Run position.

Opening and Closing the Power Sliding Door(s) (if equipped)

- Press  on the RKE transmitter to open the passenger-side power sliding door. Press the button again to close the door.
- Press  on the RKE transmitter to open the driver-side power sliding door. Press the button again to close the door.

Note: All doors will unlock when opening the sliding door(s) with the RKE transmitter.

See Section 2 of your Owner Manual.

Remote Vehicle Starter System (if equipped)

This feature allows you to start the engine from outside the vehicle by using the RKE transmitter. (Normal remote start transmitter range is within approximately 200 feet of the vehicle.) You can also preset the vehicle's climate control system to heat or cool the vehicle interior.

The engine will run for about 10 minutes before turning itself off, but can be extended 10 minutes more by performing another remote start sequence at any time. After two consecutive remote starts, no additional remote starts are allowed until the vehicle has been started with the ignition key.

The Remote Vehicle Starter System will not operate if the hood, liftgate or a door is open, or if the key is in the ignition.

Starting the Vehicle

1. Aim the RKE transmitter at the vehicle.
2. Press and release the **L** (Lock) button on the RKE transmitter.
3. Immediately press and hold the **Ⓜ** (Remote Start) button for about two seconds.
4. When the vehicle starts, the parking lamps will light and stay on while the engine is running.
5. Repeat these steps for a 10-minute time extension.

After a remote start, the key must be inserted in the ignition and turned to the Run position before driving.

Canceling a Remote Start

If you wish to turn off the engine instead of driving after a remote start, perform one of the following functions:

- Press and hold the **Ⓜ** button until the parking lamps turn off.
- Press and release the Hazard Warning Flashers button inside the vehicle. Press the button again to turn off the hazard warning flashers.
- Turn the key in the ignition switch to the Run position and then Off.
- The engine will automatically stop when time expires.

Note: If your vehicle is equipped with the Remote Vehicle Starter System, instructions for operating this feature are provided on a tag that can be attached to your vehicle's key chain for easy reference.

ENTERTAINMENT

Audio Systems



Setting the Time

1. Press and hold the Hour (H) or Minute (M) button, located on the lower-left corner of the radio, to enter the clock mode. ADJUST CLOCK will be displayed.
2. Press and hold the H button until the correct hour appears on the display.
3. Press and hold the M button until the correct minute appears on the display.

Radio Data System (RDS)

RDS has the capability to:

- Seek only stations with the types of programs you want to listen to
- Seek stations with traffic announcements
- Receive announcements concerning local and national emergencies
- Receive and display messages from radio stations

RDS features are available for use only on FM stations that broadcast RDS signals. These features will work only when the RDS information is available.

Radio Controls

Top Knob (Power/Volume): Press this knob to turn your audio system on or off. Turn this knob to increase or decrease the volume.

 **(Tune):** Turn this knob to select radio stations.

 **(SEEK SCAN):** Press the right or left arrow to go to the next or previous station and stay there.

To scan radio stations, press and hold either arrow for two seconds until a single beep sounds and FREQUENCY SCAN appears on the display. To scan preset stations, press and hold either arrow for four seconds until two beeps sound and PRESET SCAN appears on the display. Press either arrow again to stop scanning.

BAND: Press this button to switch to FM1, FM2, XM1, XM2 (if equipped) or AM.

CD AUX (Auxiliary): Press this button to play a CD instead of the radio. This button also is used to switch between a CD in the CD player and a CD or DVD in the DVD player.

i (Information): When using the Radio Data System (RDS), press this button to display RDS options, such as station name, RDS station frequency, Program Type (PTY), and the name of the program, if available.

CAT (Category): When using XM Radio, press this button to retrieve many different categories of information.

TRAF (Traffic): When using the Radio Data System (RDS), press this button to seek a station that broadcasts traffic announcements.

AUTO EQ (Automatic Equalization):

Press this button to select customized equalization settings.

 **(Automatic Volume):** Use this control to automatically adjust audio system volume to compensate for vehicle speed.

Note: During extended use, your vehicle's radio buttons may become warm to the touch. This is normal.

Presetting Radio Stations

You can preset up to 30 radio stations (six FM1, six FM2, six XM1, six XM2 and six AM) by using the radio's six numbered buttons.

1. Press BAND to select FM1, FM2, XM1, XM2 or AM.
2. Tune in a desired station.
3. Press AUTO EQ to select the equalization, if desired.
4. Press and hold one of the six numbered buttons until you hear a beep.

Repeat the steps for each button.

CD Player Controls

Your vehicle's audio system features an MP3-capable CD player.

 **(Tune):** Turn this knob to go to the next or previous track.

 **(Reverse):** Press and hold this button to reverse the current track.

 **(Fast Forward):** Press and hold this button to fast-forward through the current track.

RDM (Random): Press this button to hear the tracks in random order. Press the button again to turn off random play.

RPT (Repeat): Press this button to hear a track again. Press the button again to turn off repeat play.

≡ (Song List): Press and hold this button to save and play up to 20 track selections in the song list.

MUTE (if equipped): Press this button to silence the audio system. Press the button again to turn the sound on.

⊞ (Load) (if equipped): Press this button to load CDs into the six-disc CD player.

△ (Eject): Press this button to eject a CD. (Eject operates with the ignition or radio off.)

⏮ (SEEK) ⏭: Press the left arrow to go to the start of the current track or the right arrow to go to the next track. Press and hold either arrow button to continue moving backward or forward through the CD.

To scan a CD, press and hold either arrow button for more than two seconds until SCAN is displayed. The first 10 seconds of each track will be played. Press and hold either arrow button for more than four seconds until CD SCAN is displayed to play the first 10 seconds of the first track of each loaded CD. Press either arrow button to stop scanning.

BAND: Press this button while a CD is playing to listen to the radio instead.

AUTO EQ (Automatic Equalization): Press this button to select the desired equalization setting while playing a CD. The setting will be automatically recalled whenever a CD is played.

See Section 3 of your Owner Manual.

Multiple-Disc CD Changer (if equipped)



Loading CDs

1. Turn on the ignition.
2. Press the **⊞** button once to load one disc. Press and hold the **⊞** button to load multiple discs.
3. The unit will beep and INSERT CD # will be displayed.
4. Insert a CD partway into the slot, label side up; the player will pull in the CD.
5. LOADING CD # will be displayed.
6. Follow the display prompts to load additional CDs.

The last CD loaded will automatically begin to play. Press the radio preset button (1–6) to play a specific CD.

To eject one disc, press the **△** button once. To eject multiple discs, press and hold the **△** button.

Note: CDs with any affixed labels may jam in the CD player. Label a CD using a permanent marker. If more than one CD is inserted into the slot at one time, or if scratched or damaged CDs are played, the CD player could be damaged. When using the CD player, use only CDs in good condition without labels; load one CD at a time; and keep the CD player and the loading slot free of foreign materials, liquids or debris.

See Section 3 of your Owner Manual.

Touch Screen Navigation Entertainment System (if equipped)

Your vehicle's Navigation Entertainment System provides you with detailed maps of all major highways and roads throughout the United States. After you enter a destination, the system provides turn-by-turn instructions for reaching your destination. In addition, the system can help you locate a variety of points of interest, such as banks, airports, restaurants and more.

See your Navigation Entertainment System Owner Manual for operating instructions.

See *Section 3 of your Owner Manual*.

Rear Seat Entertainment (RSE) System (DVD Player) (if equipped)



The Rear Seat Entertainment (RSE) System can play a DVD, CD or MP3 disc. All passengers can listen to the system using the vehicle speakers. Passengers in the 2nd- and 3rd-row seats also can listen using the wireless headphones (if equipped) or by plugging owner-provided wired headphones into the two headphone jacks.

Using the DVD Player

1. Switch the ignition to either the Accessory or Run position.
2. Insert a disc into the overhead DVD player.
3. Fold down the screen to a vertical position.
4. All DVD, CD and MP3 discs will begin playing automatically. When playing a DVD, you may be required to press the ► (Play) button on the DVD player or the remote control (if equipped) to start playing the movie if the DVD stops at a menu screen.

Using the Vehicle Speakers

1. Turn on the radio.
2. Press the CD/AUX button on the radio until DVD is displayed.
3. Adjust speaker volume using the radio volume control knob.

Using the Wireless Headphones (if equipped)

1. Move the headphone switch to Channel 1 to listen to the disc in the DVD player.
2. Turn on the headphones.
3. Adjust the volume using the dial on each headphone.

Using Owner-Provided Wired Headphones

1. Insert the headphone connector into the left or right headphone jack behind the DVD screen (next to the auxiliary jacks).
2. To adjust the volume:
 - Press the  (wired headphone) button on the DVD player until the Wired Headset Volume is displayed each time you want to

adjust the volume (the left headphone is highlighted first, followed by the right headphone).

- Use the ◀▶ arrow keys on the DVD player to increase or decrease the volume.

The vehicle's Rear Seat Entertainment System is capable of many modes of operation. Front-seat, 2nd- and 3rd-row passengers can listen to different audio/video sources at the same time using the Rear Seat Audio controls and the wireless headphones (if equipped).

Note: Front-seat passengers have control over an audio source if the rear-seat passengers are listening to the same source through the RSE System.

Parental Controls

While a disc is playing in the DVD player or while using Rear Seat Audio (RSA), press the Parental Control button, located behind the video screen next to the auxiliary jacks, to stop the video and mute the audio. The DVD and RSA lights will flash. It will also disable all other button operations except the Eject button. Press the button again to restore normal operation.



If the DVD player is off and a disc is in the player, pressing the Parental Control button will turn on the DVD player and automatically resume playing the disc if the vehicle ignition is in the Run or

Accessory position. This allows front seat passengers to turn on the DVD player while younger passengers remain safely buckled in the 2nd- or 3rd-row seat.

See Section 3 of your Owner Manual.

Steering Wheel Audio Controls (if equipped)



The steering wheel-mounted audio controls allow you to adjust the radio and CD player while keeping your hands on the wheel.

◀▶ (**Seek**): Seeks radio stations or the next track on a CD.

BAND: Selects AM, FM or XM Satellite Radio (if equipped).

1-6: Cycles through the radio presets or loaded CDs.

⏏ (**Mute**): Mutes the volume.

▶ (**CD/AUX**): Switches between a CD and DVD.

◀ (**Volume**): Adjusts audio volume.

See Section 3 of your Owner Manual.

CONVENIENCE

Daytime Running Lamps (DRL)



Your vehicle is designed so that front lights are always on when the ignition is in the Run position and the vehicle is in any gear except Park. At night, or in reduced light such as tunnels, an automatic headlamp control turns on the front and rear lights. The DRLs can be disabled by shifting into Park.

See Section 3 of your Owner Manual.

Interior Lamps

The interior lamps control knob is located on the instrument panel to the left of the steering wheel.



 **(On):** Turns on the interior lamps.

 **(Door):** Enables the interior lamps to illuminate when a door is opened and the key is removed from the ignition.

 **(Override):** Disables the interior lamps.

 **(Instrument Panel Brightness Control):** Turn the knob clockwise to brighten the lights and counterclockwise to dim them.

See Section 3 of your Owner Manual.

Cruise Control



The cruise control lever is attached to the right side of the steering column, permitting convenient tap up/tap down speed adjustments.

Turn On the Cruise Control System

- To turn on cruise control, press in the  **ON/OFF** button at the end of the cruise control lever. The white stripe on the button will not be visible when cruise control is turned on.

Setting Cruise Control Speed

- Accelerate to your cruising speed (must be over 25 mph).
- Push down on the cruise control lever to the **▼SET —** position and release it.
- Remove your foot from the accelerator pedal.
- The cruise control symbol on the instrument cluster will illuminate.

Adjusting Cruise Control Speed

Tap or hold the cruise control lever up (**▲RES +**) to increase speed or down (**▼SET —**) to decrease speed.

Canceling Cruise Control Speed

- Press the brake pedal to cancel your set cruising speed, or
- Pull the cruise control lever toward you to cancel your set cruising speed.
- Pull up the cruise control lever to resume (▲RES +) your set cruising speed.

Turn Off the Cruise Control System

- To turn off cruise control, press in the  ON/OFF ◀ button again.

Note: If you accelerate above the set cruising speed and maintain that speed for at least one minute, your set speed will be canceled and the cruise control symbol on the instrument cluster will turn off.

See *Section 3 of your Owner Manual.*

Window Washer Fluid

Your vehicle's windshield washer fluid reservoir, located under the hood, sends washer fluid to both the windshield and the rear window.

When the reservoir is almost empty, the rear washer will no longer receive fluid, thereby conserving fluid for the windshield. It's recommended to refill the reservoir when you notice the rear washer is not receiving any fluid.

See *Section 3 of your Owner Manual.*

Passenger Air Bag Status Indicator

Your vehicle is equipped with a Passenger Sensing System located in the front passenger seat for the front passenger frontal air bag, and a passenger air bag status indicator located on the instrument panel center stack.

Note: It is recommended that children not be placed in the front passenger seat, even with the Passenger Sensing System. All children should be secured in a rear seat, including an infant riding in a rear-facing infant seat, a child riding in a forward-facing child seat or an older child riding in a booster seat.

See *Sections 1 and 3 of your Owner Manual.*

Universal Home Remote (if equipped)

Universal Home Remote is a combined universal transmitter and receiver that can activate up to three devices such as garage door openers, entry door locks, gates and security systems.

It's recommended that you read the instructions in your Owner Manual completely before attempting to program any of the three channels on the Universal Home Remote. The engine should be turned off when programming the remote.

Note: Do not use the Universal Home Remote with any garage door opener that does not have the "stop-and-reverse" feature or any opener manufactured before April 1, 1982.

See *Section 2 of your Owner Manual.*

OnStar®

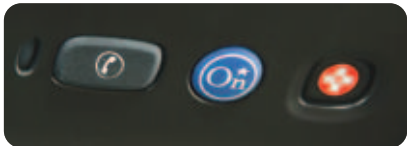

The OnStar system with Directions and Connections and Turn-by-Turn Navigation provides in-vehicle safety, security and phone services, available 24 hours a day, 7 days a week. These services are easily accessed through the three OnStar buttons in your vehicle. For more information about OnStar features, refer to the OnStar Owner's Guide and enclosed audio CD located in your glove box.



See Section 2 of your Owner Manual.

Power Sliding Doors (if equipped)



On equipped vehicles, driver-side and/or passenger-side Power Sliding Doors provide added operating convenience. The Power Sliding Doors may be controlled by:

Switches on the Overhead Console

-  **(Driver-side door):** Press the top of the switch (closer to you) to open the door; press it again to close.
-  **(Passenger-side door):** Press the top of the switch (closer to you) to open the door; press it again to close.

-  **(Disable function):** Press the bottom of either power sliding door overhead switch (closer to the windshield) to disable that door's power operation (the doors will still operate manually).

Note: Pressing the disable function button disables the power door switches only. It does not disable the power door buttons on the RKE transmitter.

Door Switches

- Located inside the van, just in front of each sliding door.
- Press the switch for the corresponding door to open; press it again to close.

RKE Transmitter

- The RKE transmitter (key fob) buttons with van icons facing left and right operate the corresponding driver-side and passenger-side doors.
- Press the button to open the door; press it again to close.

Door Handle (inside or outside)

- Pull a handle with the door opened or closed and it will energize and continue operation without further assistance.

Note: If you accidentally open the driver-side power sliding door when refueling the vehicle, the door will open eight to 10 inches, stop and power will be cut off. A chime will sound. This is normal operation to prevent damage to the vehicle while the fuel door is open. To restore power, close the driver-side power sliding door manually and close the fuel door. The door will now resume normal operation.

Power Sliding Door Obstructions

The power sliding door will automatically reverse to the open position if anything obstructs its path while it is closing. Resistance to the sliding door must be as great as or greater than the force of the closing door to cause it to reverse. The force of the closing door increases significantly as the door approaches the final latched position. Pressing the door switch next to the corresponding sliding door, or on the RKE transmitter, will stop a closing power sliding door. The door also may be stopped immediately by pressing the power sliding door disable switch on the overhead console.

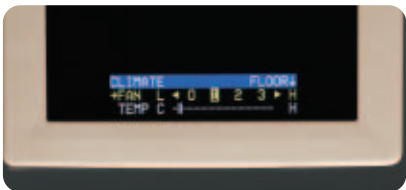

See *Section 2 of your Owner Manual*.

Rear Seat Climate Control with the RSE System (if equipped)



The driver or the rear seat passengers can operate the rear seat climate control. The driver can operate the rear seat climate control by using the rear fan switch located at the bottom center of the front climate control panel.

When the rear fan switch on the front climate control panel is set to the AUX position, rear seat passengers can adjust the fan speed and temperature using the controls on the Rear Seat Entertainment (RSE) System control panel. If the rear fan switch is not in the AUX position, DISABLED will be shown on the DVD screen.

To decrease or increase the rear fan speed or temperature, press the  (fan) /  (temperature) button on the RSE control panel, and then press the arrow buttons to select the desired function and adjust the settings.

See *Section 3 of your Owner Manual*.

Folding Rear Seats

Your vehicle has two captain's chairs in the 2nd row and a 50/50 split bench seat in the 3rd row.

2nd-Row Captain's Chairs

The captain's chairs can be reclined, adjusted forward or rearward, or folded. Fold the captain's chairs for easier access to the 3rd-row seats.

To fold a 2nd-row captain's chair:

1. Pull up the adjustment bar located at the bottom front of the seat and move the seat to its rearmost position.
2. Pull up the recline lever, located on the outboard side of the seat, and fold the seatback all the way forward.

The captain's chairs feature seatback storage units for the wireless headphones and other items. The covers of the storage units can be removed for cleaning. The storage units also are provided on front-row captain's chairs.

Note: If your vehicle has 2nd-row captain's chairs with side air bags, the chairs cannot be removed.

3rd-Row 50/50 Split Bench Seat

To fold the seats for more cargo room:

1. Pull the seatback latch (A) located on the back of the seat.
2. Fold the seatback forward. The headrest will flip rearward if it contacts an object when the seat is folded forward.
3. Once the seatback is folded down, the easiest way to latch it (or unlatch it if folding up the seat) is to stand next to it with the sliding door open and the 2nd-row seat folded forward.
4. Push down on the folded seatback to ensure that it is secure.



See Section 1 of your Owner Manual.

Side-Folding Utility Tray



The utility tray is located on the right side of the driver's seat and the driver-side 2nd-row captain's chair (if equipped). It features a tray and cupholders. The cupholder liners may be

removed to accommodate larger beverage containers and to be hand-washed. Both utility trays can be folded down for easy access to the 2nd- and 3rd-row seats.

Raising the Tray Table

- Pull up on the tray table to lock it into position.

Lowering the Tray Table

- Pull the release handle located at the front of the tray table; then lower it into the stowed position.

See Section 2 of your Owner Manual.

Convenience Center (if equipped)

The rear convenience center behind the 3rd-row seat provides extra storage space for a variety of items.

To open the convenience center cover, pull up on the cover latch. The black prop rods will hold the cover up in place.

To close the convenience center cover, pull the prop rod toward you while holding the cover; then lower the cover to close it.

An illustrated instruction label is located on the inside of the driver-side cover.

See Section 2 of your Owner Manual.

Child Restraints (LATCH)

Your vehicle is equipped with LATCH anchors, and may have top tethers for use with a LATCH compatible child restraint. If your child restraint is not compatible with the LATCH system, you may still use it by installing the child restraint with the seat belt system.

Choose a child seat that is appropriate for the child's age and size (weight and height).

See *Section 1 of your Owner Manual*.

Overhead Rail System Modules (if equipped)

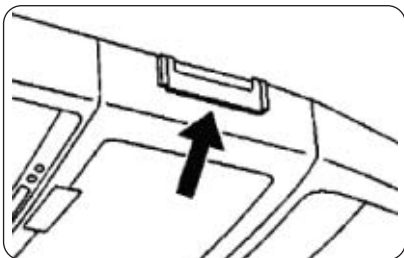

Overhead rail system storage modules featuring a variety of accessories are available from your dealer. The storage modules do not slide on the rails, but can be removed and repositioned.

Installing a Storage Module

1. Place the storage module on the rails in the desired location.
2. Push firmly upward on the module while supporting it with one hand.
3. The module will snap into place.

Removing a Storage Module

1. Support the storage module with one hand.
2. Pull each latch up and away from the module.

See *Section 2 of your Owner Manual*.

115-Volt Power Outlet (if equipped)



The 115-volt power outlet located in the rear trim panel just behind the 3rd-row seat on the passenger side provides convenient plug-in power to run electronic equipment such as video games, a small TV or a cell phone charger.

See *Section 3 of your Owner Manual*.

Air Inflater Tools (if equipped)

The air inflator unit is located in the rear compartment on the driver's side of the vehicle, behind an access cover. It can be used to inflate tires, balls and other items.

The inflator kit includes an air hose and three nozzle adapters.

See *Section 5 of your Owner Manual*.

Ultrasonic Rear Park Assist (URPA) (if equipped)

Your vehicle's Ultrasonic Rear Park Assist (URPA) operates when the shift lever is moved into Reverse and vehicle speed is less than 3 mph. Four ultrasonic sensors located on the rear bumper are used to detect the distance to the object. The URPA display, located near the rear window inside the vehicle, uses three color-coded lights to provide distance information to the driver.

The URPA system features a different sequence of warning lights and chimes than on previous systems.

- When in reverse, a chime will sound the first time an object is detected if the object is between 20 inches and five feet away.
- At five feet, the URPA indicator (located near the rear dome light) will display one amber light.
- As you move closer, an additional amber light will appear.
- A continuous chime will sound and two amber lights and one red light will appear when you reach 20 inches or closer.

To disable Ultrasonic Rear Park Assist, press the switch located in the overhead console.

Note: The URPA system indicator lights will flash red if it is not functioning properly. This condition is most likely caused by either dirty ultrasonic sensors (located on the rear bumper) or if your vehicle exceeds 3 mph when backing up. Under certain conditions, such as towing a trailer, you may want to turn off the Ultrasonic Rear Park Assist by using the switch on the overhead console.

See *Section 3 of your Owner Manual*.

PERFORMANCE & MAINTENANCE

Automatic Level Control (if equipped)

Vehicles equipped with automatic level control will exhibit a whirring sound under the rear of the vehicle. This is normal. Under additional rear loads (passengers or cargo), this sound indicates that the level control compressor is working — sending additional air to your rear shock absorbers to provide a level ride height.

See *Section 4 of your Owner Manual*.

Traction Control

The Traction Control system activates every time you start your vehicle.

When one or more of the drive wheels begin to spin from traction loss, the Traction Control system will apply braking to the spinning wheel(s) and may reduce engine power until traction is regained. If your vehicle becomes stuck, and rocking the vehicle is required, turn off the system.

Press the  button located on the instrument panel to turn the system off or back on.

See *Section 3 of your Owner Manual*.



StabiliTrak® – Stability Control System

StabiliTrak is an advanced computer-controlled vehicle stability enhancement system that assists with directional control of the vehicle during sudden maneuvers or low traction situations in poor weather. It is normal to hear the system working, and the system will automatically disengage cruise control when activated. StabiliTrak is always on and fully functional and does not require any driver input.

See *Section 4 of your Owner Manual.*

Proper Tire Pressure

Check all tires frequently to maintain the recommended pressure. A Tire and Loading Information label, located near the driver's door latch, shows the correct inflation pressures for your tires when they're cold. "Cold" means your vehicle has been sitting for at least three hours or driven no more than one mile.

See *Section 5 of your Owner Manual.*

Service Intervals

Your vehicle's Oil Life System indicates the need for engine oil and filter changes as necessary. Your vehicle maintenance schedule is now based on these oil change intervals as called for by the Oil Life System, not by mileage.

Refer to the recommended maintenance information in your Owner Manual for additional details about the maintenance needed in order for your vehicle to operate properly.

See *Section 5 of your Owner Manual.*

FlexFuel (E85) – Yellow Gas Cap (if equipped)

If your vehicle has a yellow gas cap, it was engineered as a FlexFuel vehicle capable of running on gasoline or E85 fuel. E85 is a blend of 85% ethanol and 15% gasoline. E85 is a high-octane, renewable fuel made primarily from corn (see livegreengoyellow.com).

Your FlexFuel vehicle automatically detects the current fuel mixture in the fuel tank and adjusts engine settings accordingly. You can fill up with gasoline or E85, regardless of which fuel is already in the tank.

E85 is not yet available at all gas stations. E85 holds less energy per gallon than gasoline, so drivers will experience lower miles per gallon and cruising range when running on E85.

Note: If your vehicle does not have the yellow gas cap, do not use E85.

See *Section 5 of your Owner Manual.*

OWNER INFORMATION**Roadside Assistance****1-800-252-1112**

TTY Users: 1-888-889-2438

As the proud owner of a new Buick vehicle, you are automatically enrolled in the Buick Roadside Assistance program. This value-added service is intended to provide you with peace of mind as you drive in the city or travel the open road.

Buick's Roadside Assistance toll-free number is staffed by a team of technically trained advisors who are available 24 hours a day, 365 days a year. The advisors can provide minor repair information or make arrangements to tow your vehicle to the nearest Buick dealer.

We will provide the following services for 4 years/50,000 miles (80,000 km), at no expense to you:

- Fuel delivery
- Lockout service (identification required)
- Tow to nearest dealership for warranty service
- Flat tire assistance
- Jump starts

In many instances, mechanical failures are covered under Buick's comprehensive warranty. However, when other services are utilized, our advisors will explain any payment obligations you might incur.

For prompt and efficient assistance when calling, please provide the following information to the advisor:

- Location of the vehicle
- Telephone number and your location
- Vehicle model, year and color
- Vehicle mileage
- Vehicle Identification Number (VIN)
- Vehicle license plate number

Buick reserves the right to limit services or reimbursement to an owner or driver when, in Buick's judgment, the claims become excessive in frequency or type of occurrence.

Roadside Assistance and OnStar

When you press the blue OnStar button, the vehicle will send your current GPS location to an OnStar Advisor who will speak to you, assess your problem, contact Roadside Assistance and relay your exact location so you will get the help you need.

My GMLink

The Buick Owner Center at My GMLink is a complimentary service for Buick owners, a one-stop resource to enhance your Buick ownership experience. Exclusive member benefits include online service reminders, vehicle maintenance tips, online owner manual, special privileges and more. Sign up today at www.mygmlink.com.

Certain restrictions, precautions and safety procedures apply to your vehicle. Please read your Owner Manual for complete instructions. All information contained herein is based on information available at the time of printing and is subject to change without notice. Copyright 2006 by GM Corp. All rights reserved.



15904890 A